

POST DETAIL

SCALE 1:25

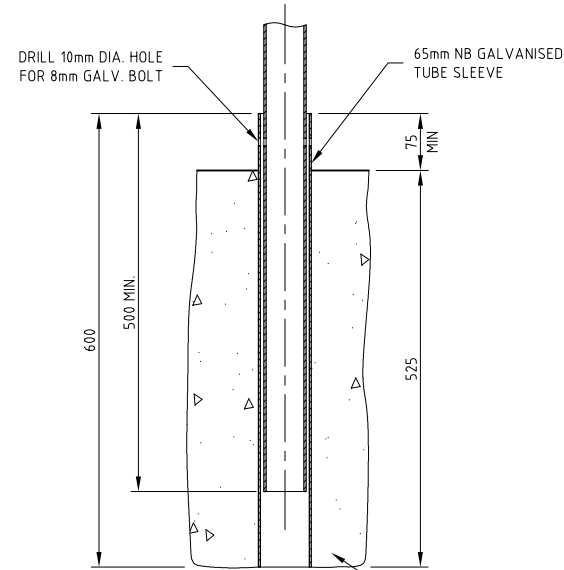

**POST HOLE DETAIL
IN SLEEVE**

SCALE 1:10

USE RAPID SET CONCRETE BACKFILL. WET CONCRETE TO BE USED AND COMPACTED THOROUGHLY AROUND FULL LENGTH OF SLEEVE.

NOTES:

1. GALVANISED STEEL TUBE USED FOR SIGN POSTS TO BE MADE FROM 50mm NB C350 GRADE STEEL WITH 2.3mm WALL THICKNESS FOR SIGNS OF AREA UP TO 0.8m.sq AND HEIGHT UP TO 2.2m. SIGNS WITH A GREATER AREA THAN 0.8m.sq TO HAVE POSTS WITH 2.9mm WALL THICKNESS.
2. FOOTING DEPTHS MAY NEED TO BE INCREASED IN SOFT GROUND TO ENSURE POST STABILITY. REFER TO TABLE 6.1 IN THE VICROADS TRAFFIC ENGINEERING MANUAL VOLUME 2 - SIGNS AND MARKINGS.
3. INSITU CONCRETE TO BE 20MP_a STRENGTH GRADE COMPLYING WITH THE REQUIREMENTS OF AS 1379.
4. SIGNS WITH LARGE SURFACE AREAS MAY REQUIRE SPECIAL FOOTING CONFIGURATIONS.
5. ALL POSTS SHALL BE BRACED WITH NUT AND BOLT AS WELL AS A ROADSIDE WEDGE, OR GIBB KEY.
6. WARNING SIGNS TO BE BRACED WITH "TRIBOLAR BOLT" ANTI VANDAL/THEFT BOLT (PRODUCT CODE TD-AVB). STREET SIGNS TO BE FITTED WITH ONE (PREFERABLY TWO) 'ANTI VANDAL' NUT AND BOLT SET.
7. WHERE POSSIBLE THE TOP OF POST SHALL NOT EXTEND PAST THE SIGN.
8. FOR LOCATION OF SIGNS REFER TO SECTION 5 IN VICROADS TRAFFIC ENGINEERING MANUAL VOLUME 2 - SIGNS AND MARKINGS.

0	APR 08	REVISED AND REISSUED	
VER	APPD.	DATE	AMENDMENT

REFERENCES:

APPROVED:
D Hannah
Manager Engineering Services
Date: April 2008



STANDARD DETAIL
SIGN POST

DRAWING No:
CGG710

AMENDMENT:
0